

**Before connecting the faucet to the water supply, flush the tubing
thoroughly to eliminate any residue /**

Antes de conectar la grifería a la distribución de agua, purgue muy bien la cañería
a fin de eliminar partículas extrañas.

Single handle lavatory faucet / Lavatorio monocomando
FV181/K1

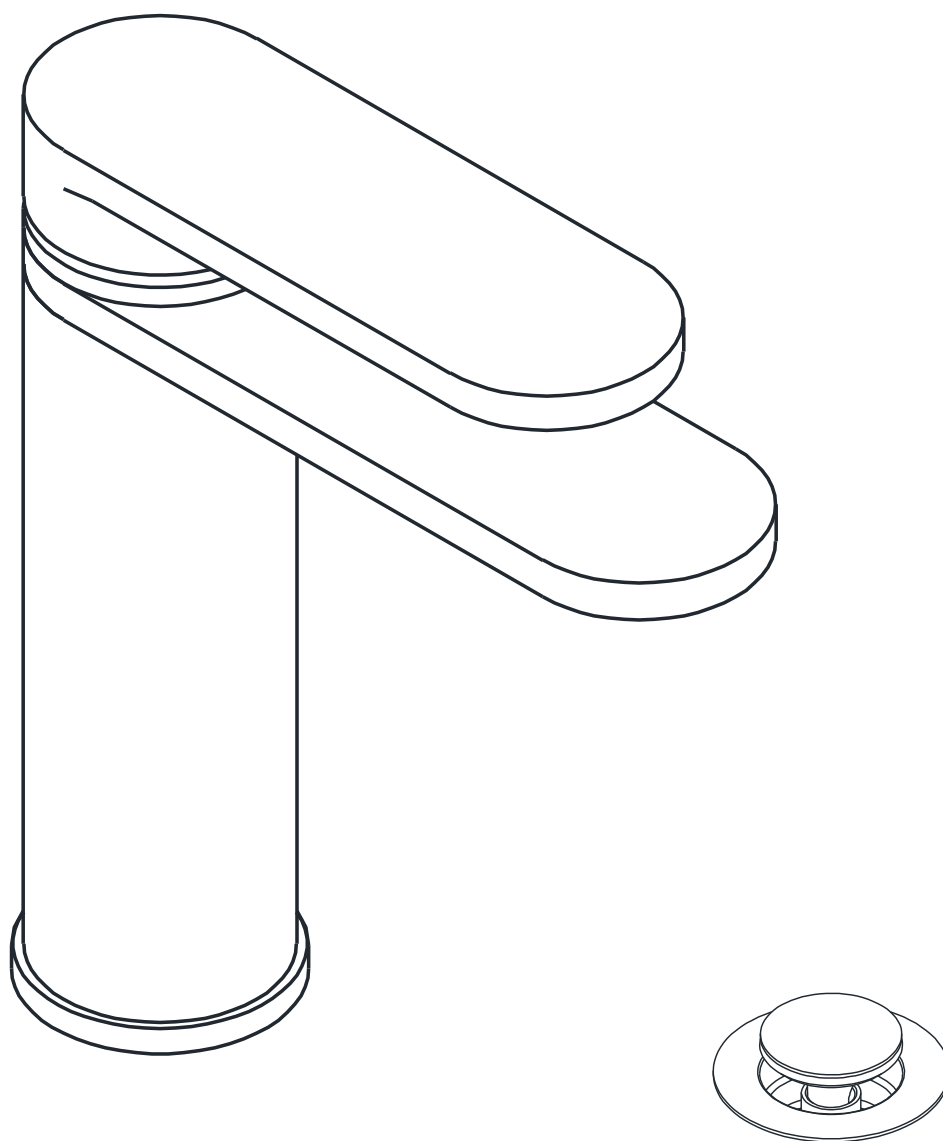

Required installation tools / Herramientas necesarias para la instalación

Provided / Provistas

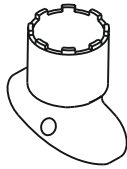

Aerator tool
Llave aireador

Not Provided / No Provistas

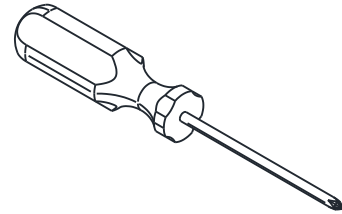

Philips screwdriver
Destornillador Philips

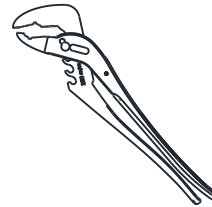

Adjustable Wrench
Llave ajustable

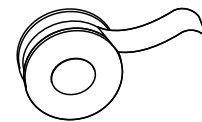

Teflón tape
Teflón

Exploded view / Vista explotada

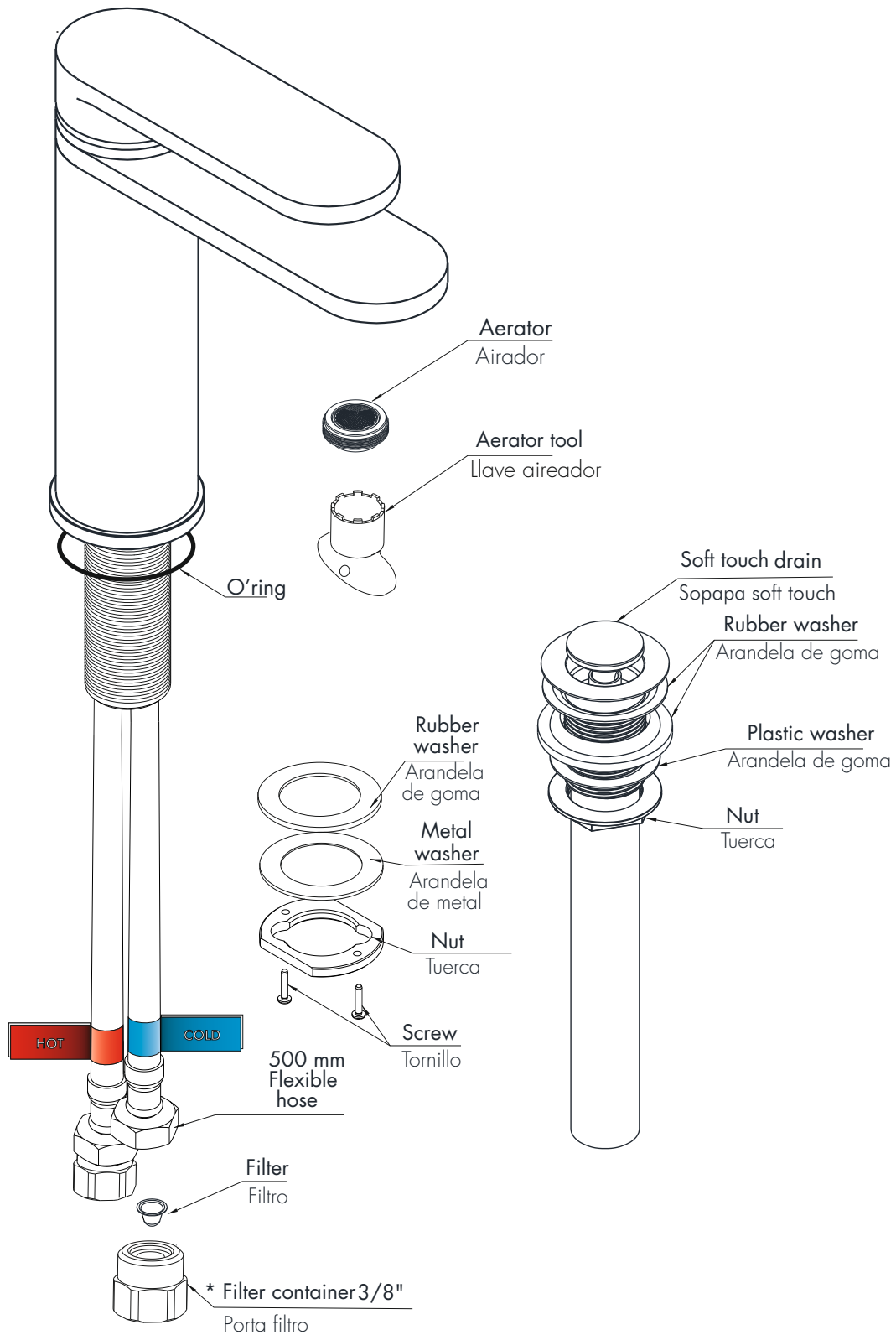

*Filter container optional 1/2" NPT or 1/2"GAS

*Porta filtro opcional 1/2" NPT o 1/2"GAS

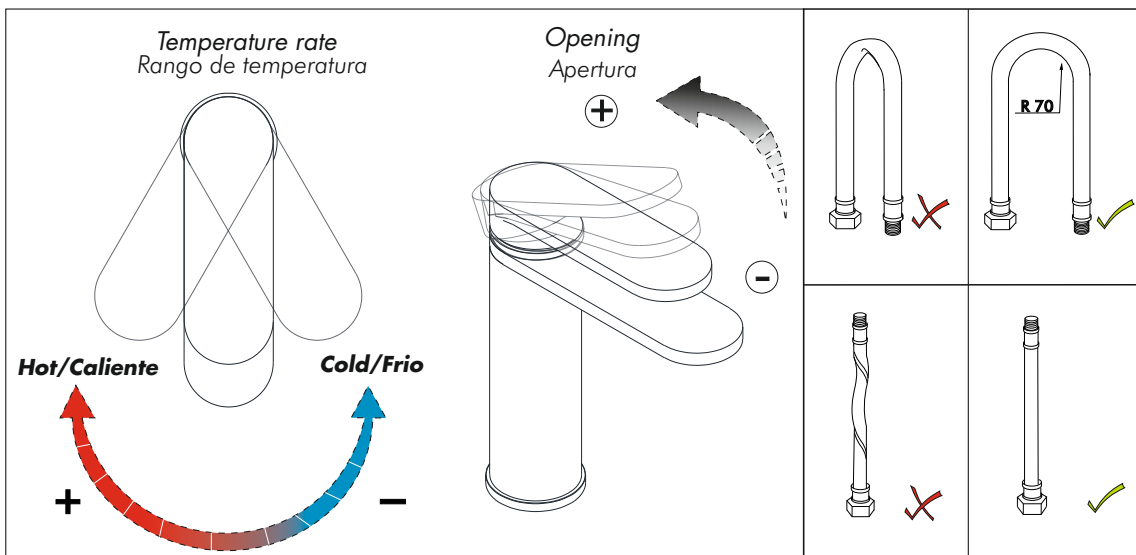
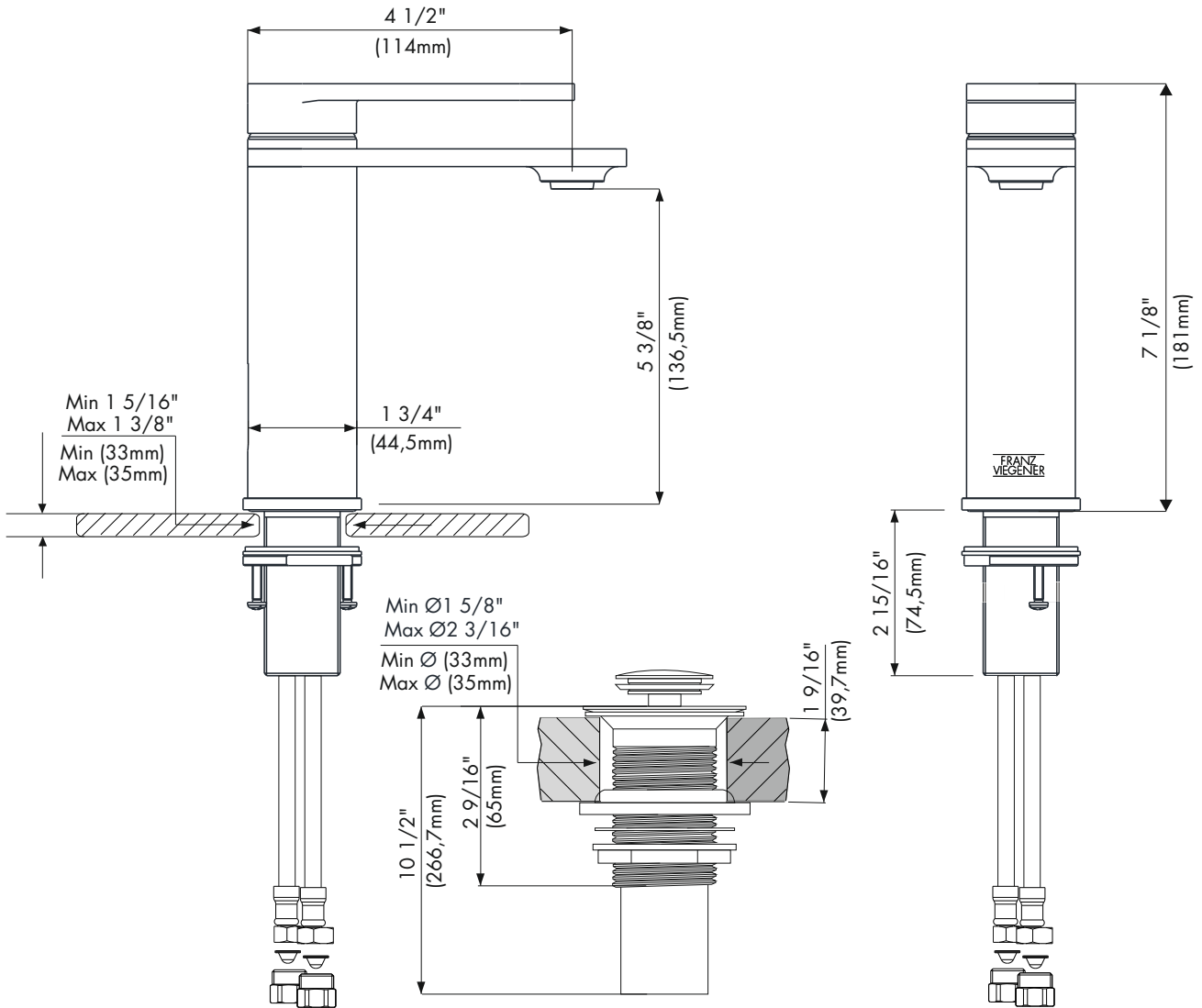

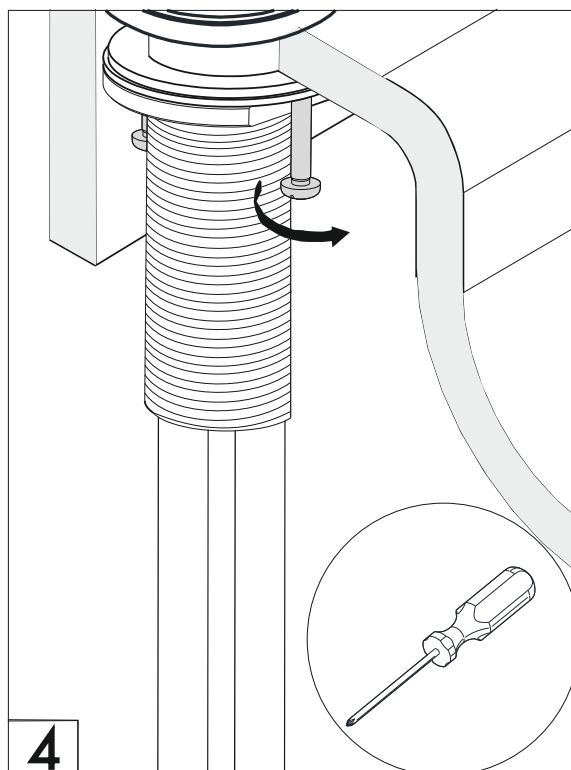
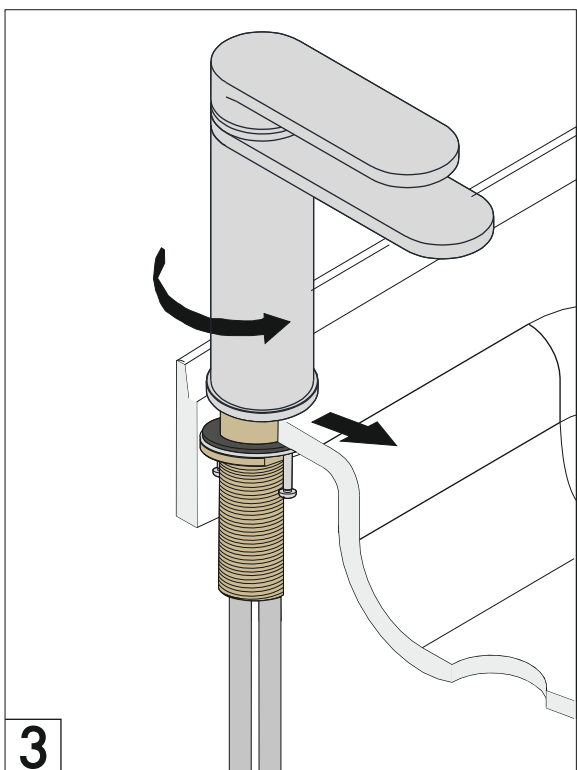
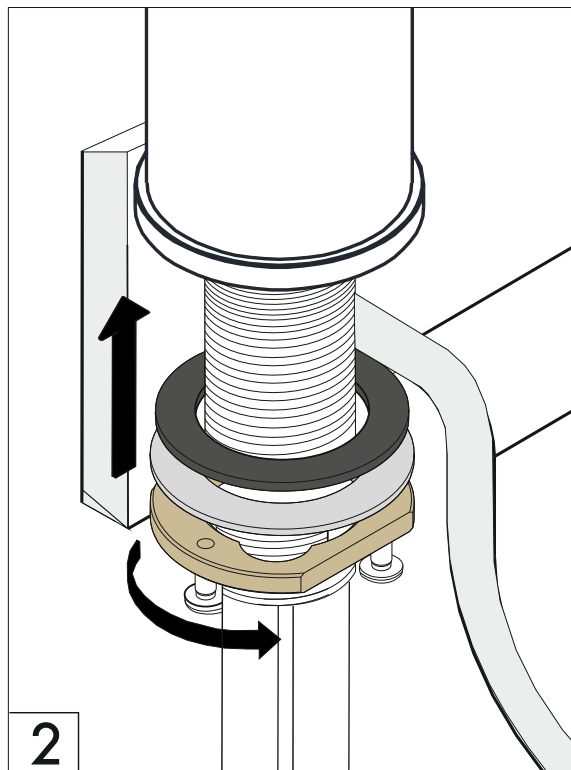
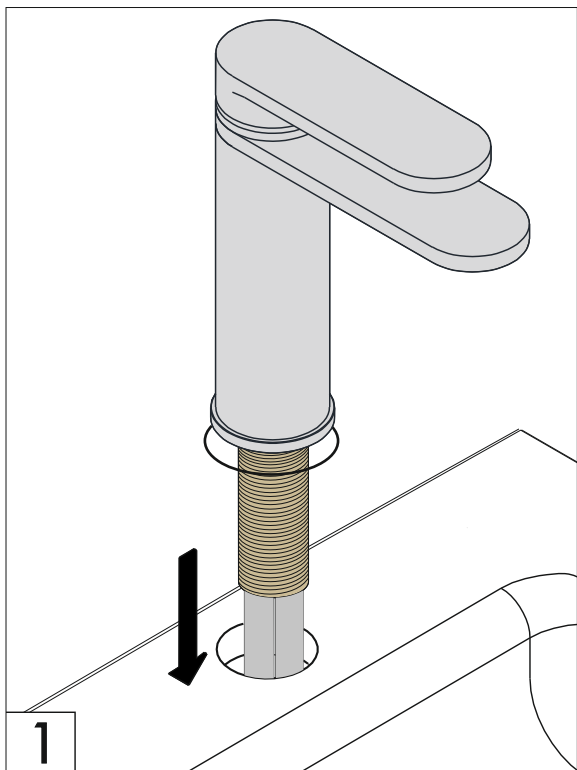

Installation / Instalación

Flexible connector installation / Instalación de conector de flexible.

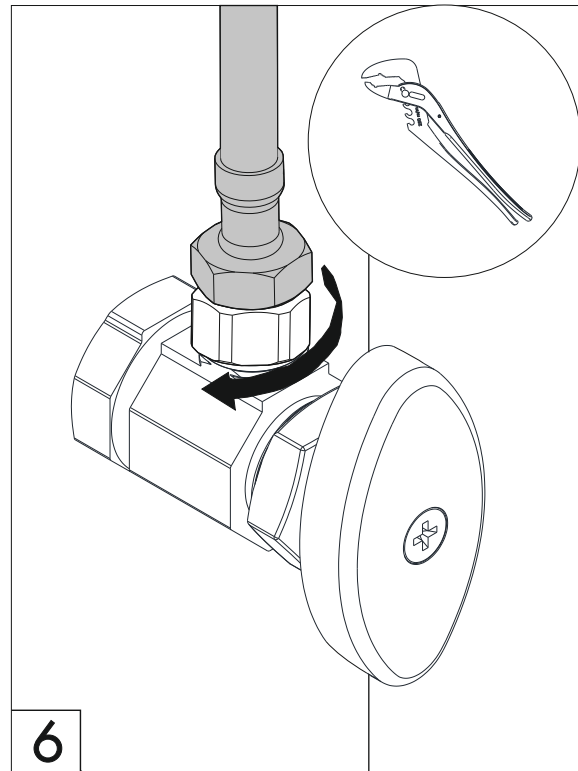
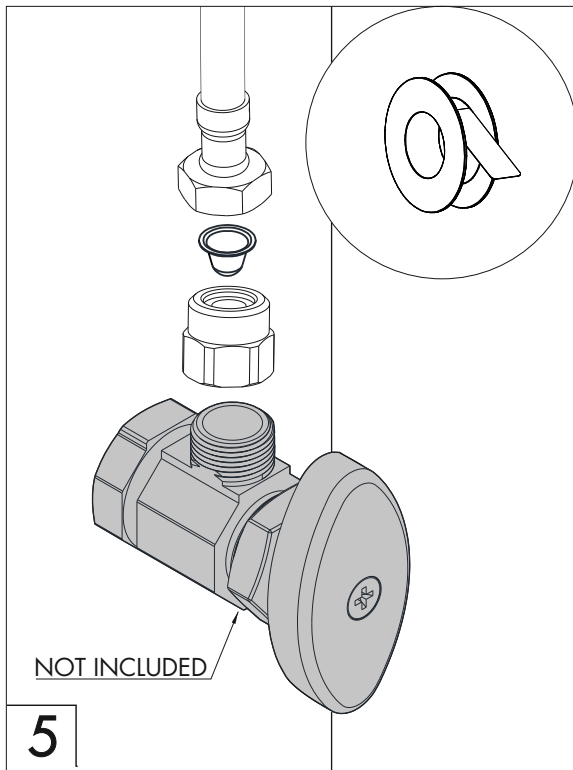

Installation / Instalación

Drain installation / Instalación de sopapa.

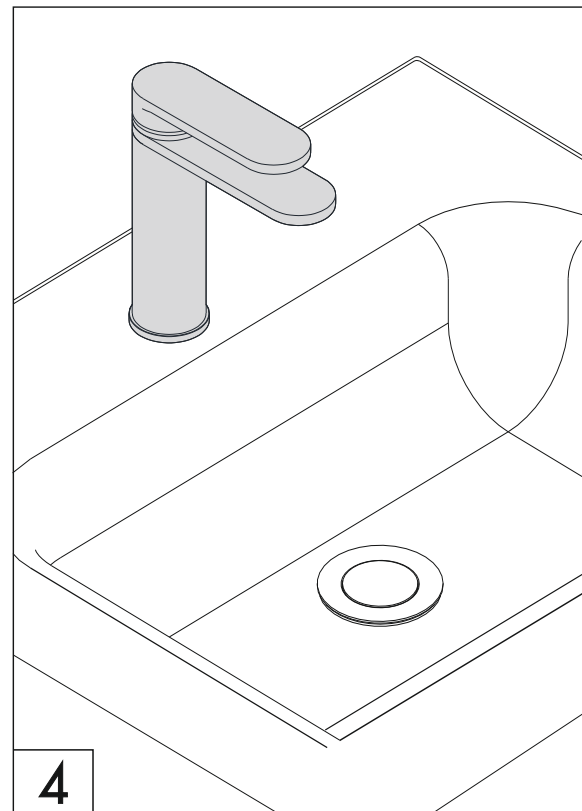
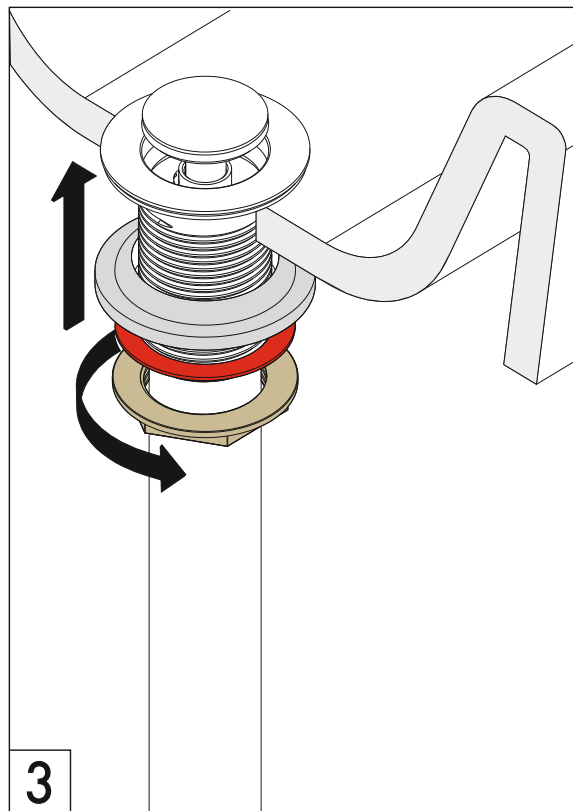
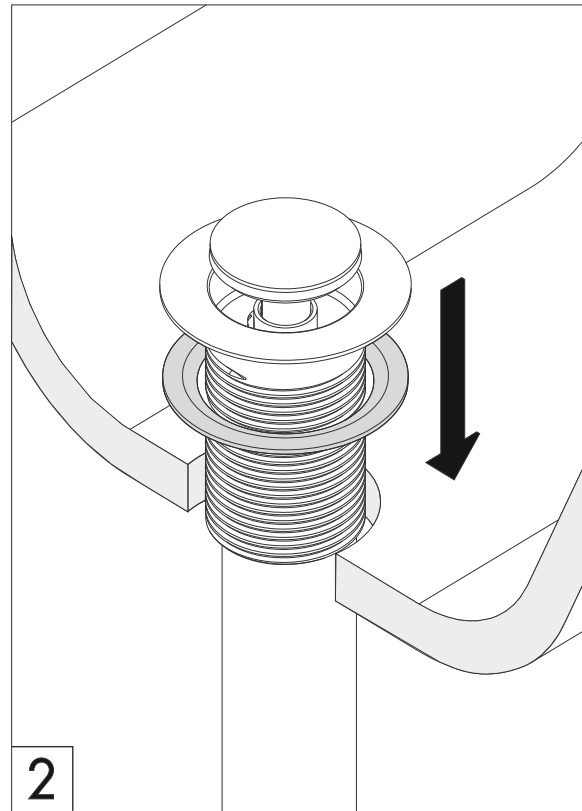
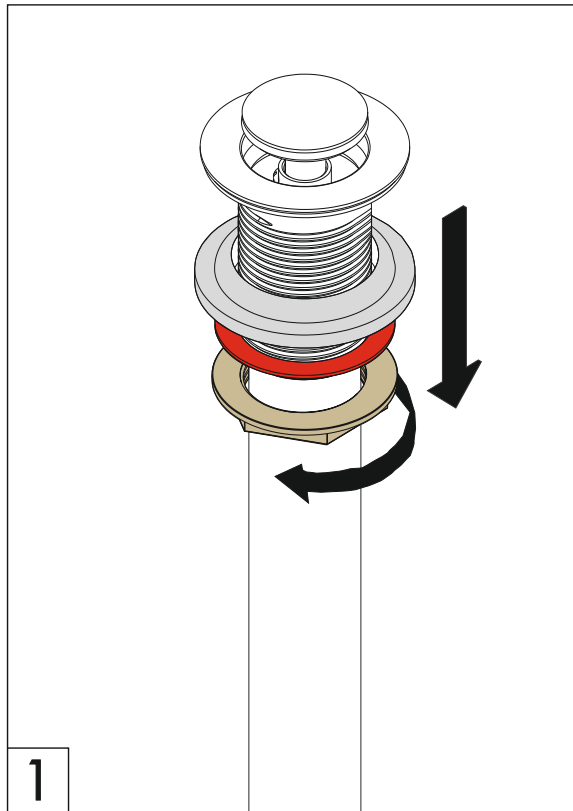

Finished installation / Instalación finalizada.



Aerator cleaning / Limpieza de aireador

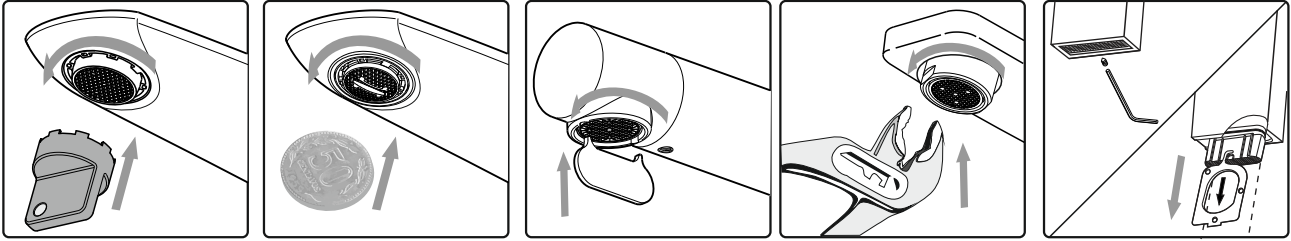

Place the corresponding tool according to the type of aerator you have and remove it. Wash it under a stream of water. If there is any sediment, place it in a glass of vinegar during the night. Put it back the next day.

Coloque la herramienta correspondiente según el tipo de aireador y remuevalo del pico. Lávelo bajo un chorro de agua. Si esta tapado colóquelo en un vaso de vinagre durante la noche. Al día siguiente vuelva a armarlo.



Attention! Do not use sharp objects to unblock the aerator
¡Atención! NO intente destapar el aireador utilizando
objetos punzantes que puedan dañarlo

WARRANTY: For more information please visit <https://franzviegner.com/warranty/>

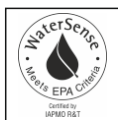
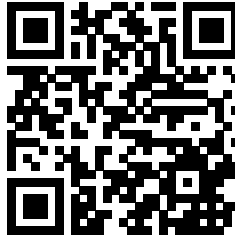

FRANZ VIEGENER Customer Service Department (800) 446-9700

Phone 847-244-3837 / Fax 847-249-4049 - info@franzviegner.com

4000 Porett Drive - Gurnee, IL, 60031-USA.

Follow us on social media!



Scan the code
to get more
information
about this line.

www.franzviegner.com